

Name: **16x1 Character LCD**
Yellow-Green LED Backlight
 Code: **MR400-010**



Features:

- 16 x 1 Characters
- STN/Transflective/Positive/Y-G
- Yellow-green/bottom-light (LED)
- Operating temp.: -10°C~+60°C
- 1/16 duty cycle, 1/5 bias
- Built-in controller (SPLC780D1 or equivalent)
- Viewing angle: 6 o'clock

Absolute Maximum Rating:

Item	Symbol	Standard value			Unit
		Min	Typ	Max	
Power supply for logic	Vdd-Vss	-0.3	--	7.0	V
Input voltage	Vi	-0.3	--	Vdd+0.3	V

Electrical Characteristics:

Parameter	Symbol	Condition	Min	Typ	Max	Unit
Supply voltage for logic	Vdd	--	4.8	5.0	5.2	V
Supply current for logic	Idd	--	--	1	--	mA
Operating voltage for LCD	Vlcd	-10°C	--	--	--	V
		+25°C	--	5.0	--	V
		+60°C	--	--	--	V
Supply voltage for Backlight	Vbl	--	--	5.0	--	V
Supply current for Backlight	Ibl	--	--	170	--	mA

Interface Pin Connections:

Pin No.	Symbol	Level	Description
1	VSS	0V	Ground
2	VDD	+5.0V	Supply voltage for logic operating
3	VO	--	Adjusting voltage for LCD driving (variable)
4	RS	H/L	A signal for selecting registers: 1: Data Register (for read and write) 0: Instruction Register (for write), Busy flag-Address Counter (for read)
5	R/W	H/L	R/W = "H": Read mode R/W = "L": Write mode
6	E	H/L	An enable signal for writing or reading data
7~14	DB0~DB7	H/L	8-bit bi-directional data bus
15	LED+	+5.0V	Power supply for Backlight
16	LED-	0V	The backlight ground

Adjusting Display Contrast:

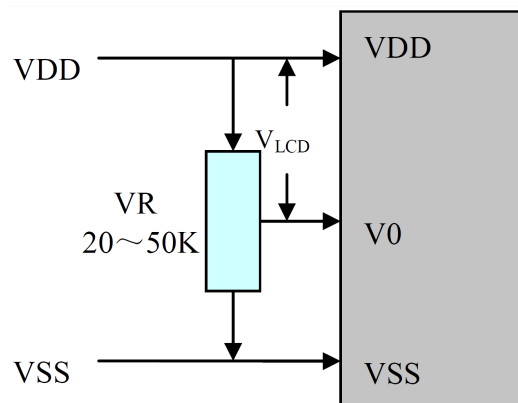

Outline Dimensions:

